



**Business Unit Mercedes-Benz Trucks**  
**Bodybuilder Information**  
 Issue 05/2026



**Mercedes-Benz**  
 Trucks you can trust

<b>Date:</b>	20.03.2026	<b>E-Mail:</b>	
<b>Author, Dept.:</b>	Bodybuilder Management	<b>Applicability:</b>	International
<b>Vehicle class:</b>	Actros / Arocs / Atego / eActros		
<b>Please note:</b>	This information bulletin and its contents are intended for international use and are not adapted to a specific country. Consequently, vehicle features and equipment items may differ in individual markets, e.g. due to registration requirements. Please address any queries to the contact person for your market. We accept no liability for the accuracy or completeness of the information provided.		

## Changes to the License Plate Flap

Dear Sir or Madam,

With the entry into force of EU Regulation (EU) 2021/535/III, all vehicles with a registration date on or after 07 July 2026 must provide an enlarged area for mounting license plates.

The required technical adjustments vary depending on the bumper variant installed.

- a) Vehicles equipped with the ProCabin (FAV) already comply with the EU regulation.
- b) For vehicles of the model series Atego (967), Arocs (964) and Actros (963 + C7F + A1V/A1Y + - FAV), the license plate flap will be extended with the production release date (DD quota) of 01 June 2026 and certified according to EU Regulation (EC) 2021/535/III.

The latest news can also be found on our website for bodybuilders at  
<https://bb-portal.mercedes-benz-trucks.com>

This circular is intended solely for your personal information and may not be passed on to third parties.  
 Information is correct to the best of our knowledge, but no responsibility can be accepted for its accuracy.

This Bodybuilder Information is valid as of the aforementioned date.

Extension of the license plate flap:

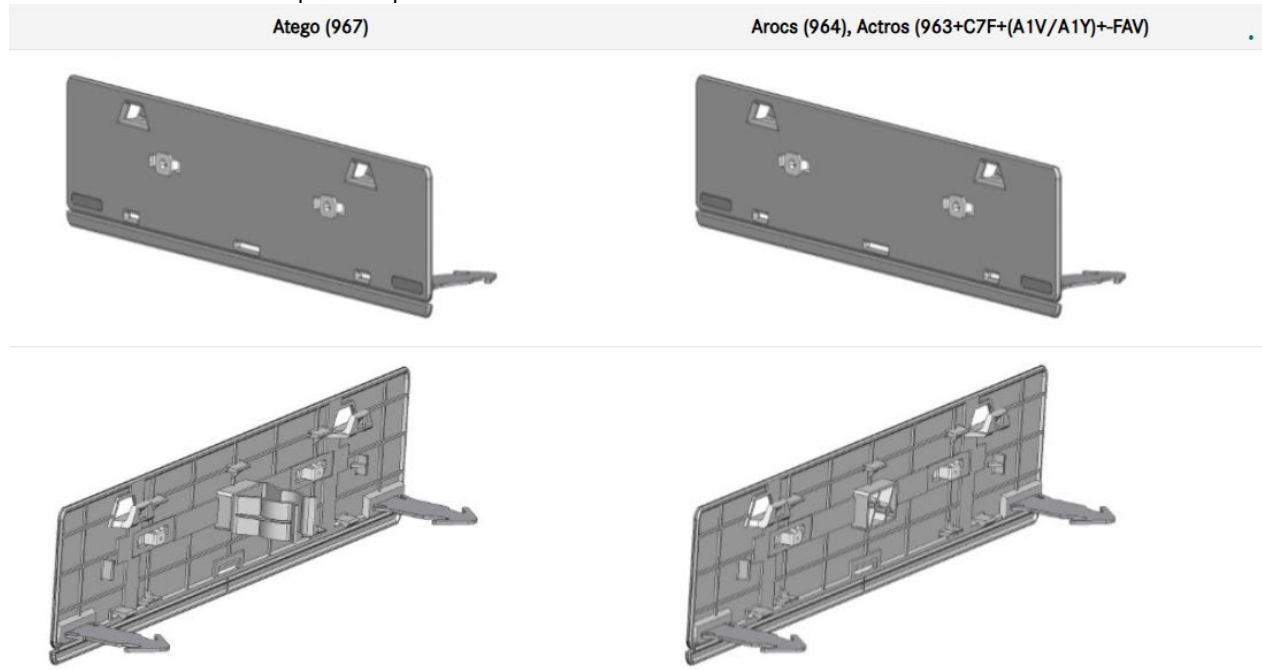

- c) For the remaining vehicles of model series 963 and eActros (983), no technical measures are required. The license plate flaps will be certified according to the new EU Regulation 2021/535/ III starting on 01 April 2026.

For the vehicles listed under section b) that are ETG-compliant, with a production date before 01 June 2026 and a registration date on or after 07 July 2026, the following applies:  
 Exceptions will be required and must be obtained through the respective local homologation representative from the local authorities.

For the vehicles listed under section b) that are non-ETG-compliant, with a production date before 01 June 2026 and a registration date on or after 07 July 2026, the following applies:  
 Whether exceptions are required must be reviewed by the local homologation representative.

If no exemption can be granted in the respective country, the license plate flap may need to be replaced.

For the vehicles listed under section c), the following applies:  
 For vehicles built before 01 April 2026, the license plate flap is still approved according to Regulation 1003/2010/EC. If these vehicles are registered on or after 07 July 2026, exemption approvals must also be reviewed in accordance with section b).

Code	Description
A1V	Cranked front axle, higher ground clearance
A1Y	Front axle, offset version
C7F	Front underride guard (ECE), aluminium
FAV	ProCabin cab version

The latest news can also be found on our website for bodybuilders at <https://bb-portal.mercedes-benz-trucks.com>

This circular is intended solely for your personal information and may not be passed on to third parties.  
 Information is correct to the best of our knowledge, but no responsibility can be accepted for its accuracy.

This Bodybuilder Information is valid as of the aforementioned date.